

A Microreactor for Microwave-Assisted Capillary (Continuous Flow) Organic Synthesis

Eamon Comer, and Michael G. Organ

J. Am. Chem. Soc., **2005**, 127 (22), 8160-8167 • DOI: 10.1021/ja0512069 • Publication Date (Web): 11 May 2005

Downloaded from <http://pubs.acs.org> on March 25, 2009

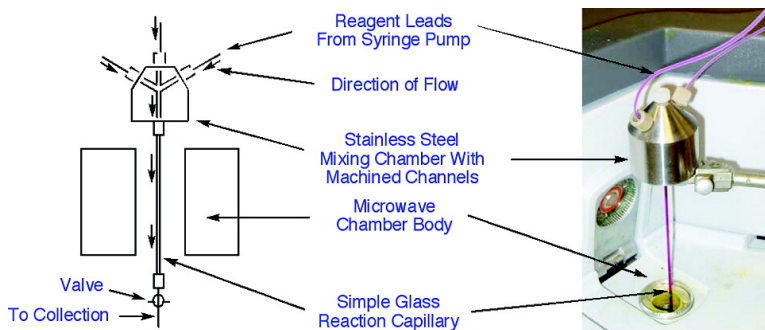

More About This Article

Additional resources and features associated with this article are available within the HTML version:

- Supporting Information
- Links to the 23 articles that cite this article, as of the time of this article download
- Access to high resolution figures
- Links to articles and content related to this article
- Copyright permission to reproduce figures and/or text from this article

[View the Full Text HTML](#)

A Microreactor for Microwave-Assisted Capillary (Continuous Flow) Organic Synthesis

Eamon Comer and Michael G. Organ*

Contribution from the Department of Chemistry, York University, 4700 Keele Street, Toronto, Ontario, Canada, M3J 1P3

Received February 25, 2005; E-mail: organ@yorku.ca

Abstract: A capillary-based flow system has been developed for conducting microscale organic synthesis with the aid of microwave irradiation. The capillary internal diameter investigated ranged from 200 to 1200 μm , while the flow rate was varied between 2 and 40 $\mu\text{L}/\text{min}$, which corresponds to the sample being irradiated approximately 4 min. Other parameters investigated include reaction concentration and power setting of the microwave. Excellent conversion was observed in a variety of cross coupling and ring-closing metathesis (RCM) reactions employing metal catalysts and in nucleophilic aromatic substitution and Wittig reactions that do not employ metals. Reactions that have solids in them do not seem to pose a significant concern for the method, such as blocked channels. It was shown that capillaries coated internally with thin films of Pd metal show tremendous rate accelerations and that the thin films themselves are capable of catalyzing Suzuki–Miyaura reactions with no exogenous catalyst added. Importantly, it has been demonstrated that reagents in separate syringes can be coinjected into the capillary, mix, and react with none of the laminar flow problems that plague microreactor (lab on a chip) technology. This paves the way to use microwave-assisted, flow capillary synthesis as a powerful and efficient means to replace “one-at-a-time” microwave synthesis to provide libraries of compounds in a scale suitable for biological screening purposes.

Introduction

The variety of synthetic transformations increases with every passing day. However, the glassware and techniques used to conduct synthesis, for the most part, mirror those used by the pioneers of organic chemistry. The great promise of combinatorial chemistry did much to advance the synthesis of many compounds simultaneously using parallel methods or mix and split techniques. In addition to the surge in equipment and technology development to support combinatorial chemistry has come a vast expansion of the development of supported reagents, scavengers, and so forth. However, all of the above development has not made individual reactions themselves faster. In fact, most of these methods, many of which are now heterogeneous, actually slow transformations down when compared to conventional solution-phase synthesis in a simple flask. Perhaps the greatest technical advancement for increasing the rate of chemical transformations is microwave (MW) irradiation, and the reasons for these enhancements are still being debated.¹

More recently, it has been discovered that some chemical transformations conducted in microscopic channels also have an, as yet, unexplained rate enhancement.² These microchannel

reactors, also called “lab-on-a-chip” or microreactors, consist of a series of interconnecting channels (typically 50–500 μm in diameter) in a glass body, although other materials have also been investigated.³ Independent reagents can be brought together through different feeder channels to the main channel, where they mix and react on their way to a downstream reservoir where the reaction products are collected and analyzed. This microreactor approach can reduce reaction times while diminishing the quantity of waste produced (e.g., solvent) because the method efficiently delivers the small quantities of material that are necessary for early stage biological screening. Other benefits of this approach include safety, as the quantities of toxic compounds are minimized, and anecdotal evidence suggests that reactions performed using this methodology can be cleaner and higher yielding than the same reactions using a typical solution-phase approach.²

For practical considerations, almost all reactions conducted in microreactors have been performed at room temperature, thus limiting the range of accessible reactions.⁴ It would be advanta-

(1) For recent reviews on the use of microwave irradiation in organic synthesis, see: (a) Kappe, C. O. *Angew. Chem., Int. Ed.* **2004**, *43*, 6250–6284. (b) Nüchter, M.; Ondruschka, B.; Bonrath, W.; Gum, A. *Green Chem.* **2004**, *6*, 128–141. (c) Swamy, K. M. K.; Yeh, W.-B.; Lin, M.-J.; Sun, C.-M. *Curr. Med. Chem.* **2003**, *10*, 2403–2423. (d) Wathey, B.; Tierney, J.; Lidstrom, P.; Westman, J. *Drug Discovery Today* **2002**, *7*, 373–380. (e) Lidstrom, P.; Tierney, J.; Wathey, B.; Westman, J. *Tetrahedron* **2001**, *57*, 9225–9283.

(2) For reviews on the use of microreactors related to organic synthesis, see: (a) Pennemann, H.; Watts, P.; Haswell, S. J.; Hessel, V.; Loewe, H. *Org. Process Res. Dev.* **2004**, *8*, 422–439. (b) Fletcher, P. D. I.; Haswell, S. J.; Pombo-Villar, E.; Warrington, B. H.; Watts, P.; Wong, S. Y. F.; Zhang X. *Tetrahedron* **2002**, *58*, 4735–4757. (c) Haswell, S. J.; Middleton, R. J.; O’Sullivan, B.; Skelton, V.; Watts, P.; String, P. *Chem Commun.* **2001**, 391–398. (3) Manz, A.; Harrison, D. J.; Verpoorte, E. M. J.; Fettingner, J. C.; Luedi, H.; Widmer, H. M. *Chimia* **1991**, *45*, 103–105. (4) There exists one example of a heated microreaction using a Peltier heater, see: Garcia-Egido, E.; Wong, S. Y. F.; Warrington, B. H. *Lab Chip* **2002**, *2*, 31–33.

geous if these reactions could be carried out at higher temperatures using microwave heating in a continuous flow, or stop flow manner.⁵ During the course of our research, two methods for continuous flow heating using microwaves on a *microscale* have been published. One of these methods involved irradiating a glass microreactor block placed in the cavity of a focused microwave⁶ and the second involved a U-shaped capillary with a heterogeneous catalyst loaded on a solid support at the bottom of the U.⁷ Both methods involved coating the outside surface of the reacting chamber with a gold film, which means that the heating used was to a large extent heat exchange and not direct heating of the solvent *per se*. In the case of the U-tube, the solid supported catalyst had to be held in place with the aid of a small glass rod inside of the U-tube to prevent it from being simply washed out.

Herein, we report a new approach to organic synthesis that consists of flowing a reaction through a short, straight capillary that sits in a microwave synthesizer. This very simple method combines the rate enhancement enjoyed by working in microchannels with microwave irradiation to expand the scope of reactions that can be conducted in a microreactor device.⁸ From a practicality point of view, the capillaries involved are actually just simple spotting tubes, available in any chemical laboratory and requiring no special fabrication. Each “reactor” costs fractions of a penny each and therefore there is no need to attempt recovery or even reuse them, although we have done so for demonstration purposes in our own chemistry.

Results and Discussion

The basic continuous flow reactor design (Figure 1) consists of a stainless steel holding/mixing chamber with three inlet ports (in this case) that merge into one outlet. The inlets are connected via Microtight fittings and Teflon tubing to an external syringe pump(s). Capillary tubes of varying internal diameters (200–1150 μm) can be interchangeably attached to the holder by Microtight fittings. After exiting the reaction capillary, the reaction flows by Teflon tubing directly to a monitoring device or collection vessel. The holder sits atop of the MW cavity of a Biotage Smith Creator Synthesizer, thus the capillary is kept in place within the irradiation chamber. The capillary is irradiated with 2.45 GHz of single mode microwave power that can be varied between 0 and 300 W, while the reaction temperature is monitored by the internal IR sensor.

One of the perceived problems of MW heating in microchannels is that the narrow vessels lead to reaction volumes too small to absorb the MW irradiation, especially in a flow situation, where the solution is in the irradiation chamber for only a very short time.⁹ To examine this, we explored the Suzuki–Miyaura coupling between 4-iodo-oct-4-ene (**1**) and 4-methoxyboronic acid (**2**) in a sealed 200 μm diameter capillary tube that was placed inside of conventional microwave reaction vial and irradiated.¹⁰ Relative to a control capillary that was not irradiated and showed no conversion, the irradiated tube

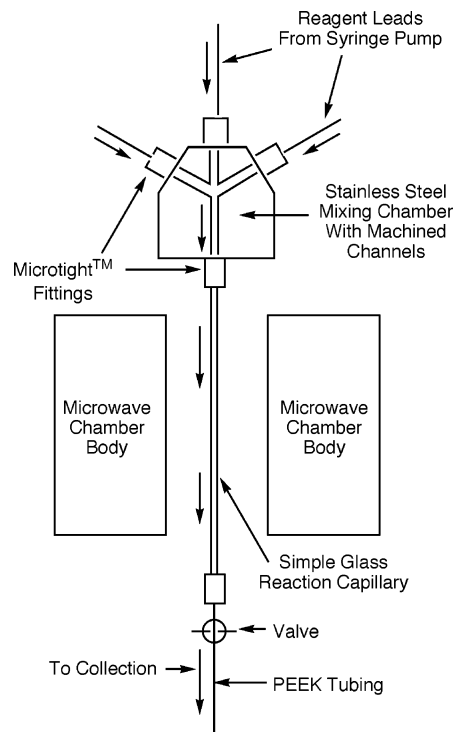

Figure 1. Continuous flow MW microreactor schematic.

gave complete conversion to product. On the basis of this result, we set out to examine Suzuki–Miyaura couplings under flow conditions while varying a number of parameters (Table 1).



For our initial flow experiment (Table 1, entry 1) we repeated the sealed capillary reaction between **1** and **2** with $(\text{PPh}_3)_4\text{Pd}$ catalyst.¹¹ The formation of **3** illustrated that the reaction mixture picked up sufficient MW irradiation under continuous flow conditions to drive the cross-coupling to a significant extent, even with THF as solvent, which is known to be a poor absorbent of MW irradiation.^{1a} When the reaction was performed under identical flow conditions except no MW irradiation was applied, no conversion took place (entry 2). Thus, in this case, there appears to be no stand-alone rate acceleration effect from the capillary itself. Full conversion of **1** to **3** was realized by reducing the flow rate, which even allowed the reaction to be run at a lower power setting (entry 3), a point more fully demonstrated in Table 4. Reducing the flow rate, we believe, simply allows kinetically slower reactions to experience the irradiation for a longer time period on their trip through the capillary.

The coupling of 4-bromobenzaldehyde (**6**) to phenylboronic acid (**7**) (entries 5 to 8) proved to be noteworthy. When the reaction was run with potassium carbonate base in DMF, the biaryl product **8** was formed in poor conversion (entry 5). Interestingly, when potassium hydroxide base was used, all other parameters being unaltered, the palladium catalyst “blacked out” during the reaction and coated the capillary wall with a thin

(5) We are aware of a large-scale, continuous flow microwave cell capable of performing *multigram* synthetic transformations, see: Wilson, N. S.; Sarko, C. R.; Roth, G. P. *Org. Process Res. Dev.* **2004**, *8*, 535–538.
 (6) He, P.; Haswell, S. J.; Fletcher, P. D. I. *Lab Chip* **2004**, *4*, 38–41.
 (7) He, P.; Haswell, S. J.; Fletcher, P. D. I. *Appl. Catal., A* **2004**, *274*, 111–114.
 (8) Organ, M. G.; Comer, E. U.S. Provisional Patent 60/605,505, 2004.
 (9) Organ, M. G. Personal communications with microwave designers and engineers at Biotage Inc., Upsalla, Sweden.

(10) A stock solution containing a solution of **1**, **2** (1.1 equiv), TBAF–THF (5 equiv), and $\text{Pd}(\text{OAc})_2$ (5 mol %) was drawn into a capillary tube with a 200 μm inner diameter. The tube was sealed and placed in a standard MW vial, and the Biotage Smith Synthesizer MW was set at 100 $^\circ\text{C}$ for 900 s to provide 100% conversion to **3** by ^1H NMR spectroscopy.
 (11) These and subsequent reactions were all performed with an MD-2000 Digital Readout microwave leakage detector directly focused on the microwave cavity (top and bottom) and the top of the microwave device including the inlet lines from the syringes to monitor any stray MW irradiation. Irradiation levels were found to well below acceptable safety standards.

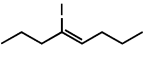
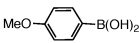
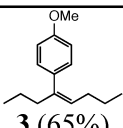
Table 1. Suzuki–Miyaura Coupling of Complete Reaction Solutions Flowed through the Microreactor Device While Being Heated by MW Irradiation

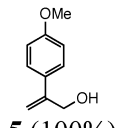
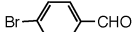
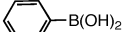
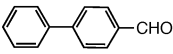
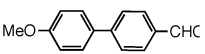
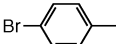
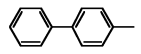
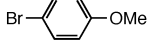
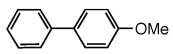
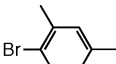
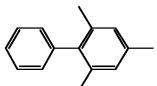
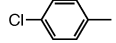
Entry	Reactant A	Reactant B	Conditions ^a	Power (W)	Flowrate $\mu\text{L}/\text{min}$ (Time) ^b	Capillary Diameter ^c μm	Product (Conversion) ^d
1			Pd(PPh ₃) ₄ TBAF, THF	160	20	200	 3 (65%)
2	1	2	Pd(PPh ₃) ₄ TBAF, THF	No irradiation	20	200	3 (0%)
3	1	2	Pd(PPh ₃) ₄ TBAF, THF THF	100	2 (27m 56s)	200	3 (100%)
4 ^e		2	Pd(OAc) ₂ KOH DMF/H ₂ O	170	15 (9m 48s)	380	 5 (100%)
5			Pd(OAc) ₂ K ₂ CO ₃ DMF/H ₂ O	170	30 (4m 13s)	1150	 8 (38%) 6 (62% recov.)
6 ^e	6	7	Pd(OAc) ₂ KOH DMF/H ₂ O	170	30 (4m 13s)	1150	8 (100%) ^f
7	6	7	Pd Coated Tube No additional catalyst used KOH DMF/H ₂ O	150	20 (5m 30s)	1150	8 (89%) ^f
8	6	7	Pd(PPh ₃) ₄ KOH DMF/H ₂ O	170	30 (4m 13s)	1150	8 (100%)
9	6	2	Pd(PPh ₃) ₄ KOH DMF/H ₂ O	170	15 (6m 50s)	1150	 9 (100%)
10 ^e		7	Pd(OAc) ₂ KOH DMF/H ₂ O	170	25 (4m 45s)	1150	 11 (94%)
11 ^e		7	Pd(OAc) ₂ KOH DMF/H ₂ O	170	25 (4m 45s)	1150	 13 (80%)
12	12	7	Pd(PPh ₃) ₄ KOH DMF/H ₂ O	170	10 (11m 17s)	1150	13 (93%)
13 ^e		7	Pd(OAc) ₂ KOH DMF/H ₂ O	100	30 (5m 20s)	380	 15 (69%)
14 ^e		7	Pd(OAc) ₂ KOH DMF/H ₂ O	170	30 (5m 20s)	380	11 (37%)

^a Solutions containing aryl halide (1.0 equiv), boronic acid (1.2 equiv), base (3.0 equiv), and Pd catalyst (5 mol %) in solvent were premixed and flowed through the microreactor device via a single inlet while being irradiated. ^b Refers to the time required for the sample to pass through the capillary from entry to exit. ^c Refers to the inner diameter (i.d.) of the capillary. ^d Percent conversion was determined by ¹H NMR spectroscopy and is relative to residual starting halide. ^e The capillary tube became coated with Pd black during the reaction. ^f The reaction mixture also contained some benzaldehyde, the product of halide reduction.

Scheme 1

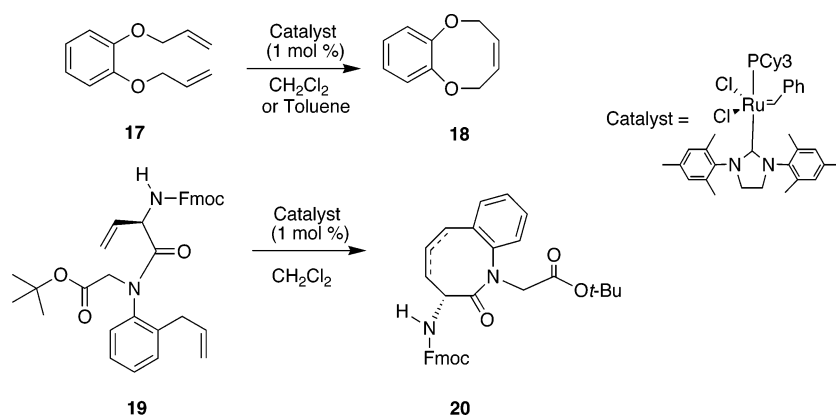

Table 2. Ring-Closing Metathesis Using the Continuous Flow Microwave Microreactor

entry	substrate/solvent	temp or power	conditions	flow rate, $\mu\text{L}/\text{min}$ (time)	product (% conversion ^a)
1	17 / CH_2Cl_2	35 °C	round-bottom flask in an oil bath	(16 h)	18 (32)
2	17 / CH_2Cl_2	150 W	380 μm capillary ^b	30 (5 min 20 s)	18 (28)
3	17 /toluene	50 W	380 μm Pd-film-coated capillary ^b	40 (3 min 54 s)	18 (35)
4	19 / CH_2Cl_2	35 °C	round-bottom flask in an oil bath	(30 min)	20 (30)
5	19 / CH_2Cl_2	200 W	std MW vial	(30 min)	20 (100)
6	19 / CH_2Cl_2	100 W	380 μm capillary ^b	40 (3 min 47 s)	20 (100)

^a Percent conversion was determined by ¹H NMR spectroscopy and is relative to residual starting material. ^b Refers to the i.d. of the capillary.

metal film (entry 6). This resulted in a dramatic increase in the temperature during irradiation as measured by the IR sensor of the microwave. For the reaction outlined in entry 5, the highest temperature recorded was 60 °C, whereas the reaction in entry 6 reached 188 °C and this was accompanied by significantly higher conversion (i.e., 38% vs 100%, respectively), albeit with some benzaldehyde produced, the result of halide reduction. It is important to point out that the IR sensor only measures the heat at the outside of the glass and it is only presumed that the measured differences reflect approximately the actual solution temperature.

It quickly became apparent that couplings where thin films formed during the course of the reaction were usually accompanied by high conversion rates.¹² What was not clear was whether the improved reactivity was solely the result of an improved heating phenomenon associated with the metal film, such as has been observed by Haswell,⁶ or if the film was itself responsible for the chemistry. Coupling between **6** and **7** was performed without $\text{Pd}(\text{OAc})_2$, but the reaction was flowed through a used capillary that had a Pd film deposited inside of it.¹³ The reaction proceeded with very good conversion (89%), which demonstrates that the deposited metal itself is capable of catalyzing these couplings without any additional catalyst. This use of thin metal films represents a new concept in catalyzing organometallic reactions. Increasing the quantity of $\text{Pd}(\text{OAc})_2$ in experiments that led to Pd film formation resulted in steadily increased temperatures, but this was not necessarily

complemented with increased conversion.¹⁴ Accordingly, it appears that an optimum temperature range exists above which the catalyst deactivates and below which there is insufficient energy to significantly increase reaction rate.

While the use of thin films in entries 6 and 7 produced impressive heating effects, a significant quantity of reduced side product accompanied the desired biaryl **8**. This problem was effectively eliminated using $\text{Pd}(\text{PPh}_3)_4$ as catalyst, which resulted in clean conversion of **6** to **8**, without the formation of a Pd film.

The strength of this new technique was further demonstrated in entry 13, when 2-bromomesitylene (**14**) was transformed to **15** in reasonable conversion (69%). Additionally, even *p*-chlorotoluene (**16**), a poor substrate for the Suzuki–Miyaura reaction,¹⁵ could be coupled to some degree using our method.

Additionally, we repeated the reaction between 4-bromobenzaldehyde (**6**) and 4-methoxyphenylboronic acid (**2**) using a known volume (0.7 mL) of the stock solution (0.15 M in **6**) and the conditions shown in Table 1, entry 9, with the exception that a flow rate of 30 $\mu\text{L}/\text{min}$ was used. This procedure required 37 min. (approximately) and afforded 20 mg of biaryl compound **11** (90% yield) after chromatography, illustrating that the method can be used to provide useful quantities of product to conduct further work with, such as biological screening.

Given the demands of high-throughput synthesis, time is obviously an important factor to consider with our technology. The times shown in parentheses in Table 1 represent the time required for a given sample to enter and exit the capillary. There is no way of knowing exactly how much time the sample actually spends being irradiated, because it is not clear how focused the irradiation source is on any one part of the capillary. It has also been suggested that the capillary could serve as an antenna and transfer the energy along its' length, which would

(12) Stadler, A.; Kappe, C. A. *Org. Lett.* **2002**, *4*, 3541–3543. In this report it was found that Pd-catalyzed coupling reactions run at high temperature led to catalyst descomposition and that the Pd black formed left a similar thin film on the glass in regular microwave vessels. However, lower yields were reported in that case in comparison to the results observed in the present study, which show a positive rate enhancement and percent conversion.

(13) The palladium-coated capillary was readily prepared in a matter of minutes by passing 0.2 mL (approximately) of a stock solution of DMF (1 mL), 2 M KOH (0.3 mL), and $\text{Pd}(\text{OAc})_2$ through a 1150 mm (i.d.) capillary at a flow rate of 30 $\mu\text{L}/\text{min}$ using the apparatus as shown in Figure 1.

(14) Table 1, entry 6 was repeated using a 10% catalyst loading to afford **8** with 69% conversion together with 5% of **6** and 26% of benzaldehyde.

Scheme 2

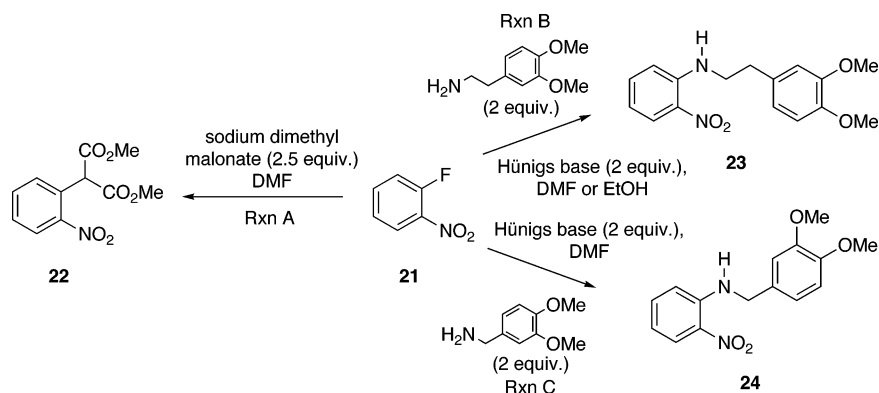

further complicate the time issue.⁹ In any case, the fact that most couplings were complete when the maximum time in the capillary was about 4–5 min demonstrates the exciting potential of this technique. Also, our ability to carry out conversions with minimal side products is very promising when compared with conventionally heated coupling reactions that require prolonged reaction times.

Having tested our method with a variety of Suzuki–Miyaura couplings, we wished to extend the scope of the technology to other metal-catalyzed processes and investigated ring-closing metathesis (RCM) (Scheme 1 and Table 2). At first glance, the RCM of substrate **17** using the capillary reactor may seem disappointing (entry 2). However, when compared to the conversion using traditional chemistry techniques (entry 1) the results are actually quite encouraging. That is, essentially the same level of conversion was obtained by flow in 5 min (entry 2) that required 16 h in an oil bath. Further, when a Pd-coated capillary was used, which was prepared as described above for the cross-coupling reactions, a slight but reproducible improvement in conversion was observed (entry 3). These results are interesting, because both toluene and dichloromethane do not “couple” efficiently with MW irradiation.^{1a} Thus, the heating effect in these instances must be due mainly to direct absorption of irradiation by the reaction components or to the Pd film on the capillary tube in the case of entry 3 (Table 2). Kiddle and co-workers established, through a heating profile, that dichloromethane is reasonably transparent to microwave energy, yet is an efficient medium for RCM reactions, which suggests direct coupling to at least one of the reacting components.¹⁶ Better conversions were achieved with **19** (entry 6), where RCM in the capillary is comparable to static MW irradiation, even though the static experiment was conducted at twice the power level (entry 5). Both MW methods were far superior to conventional heating (entry 4).

The success of our study with Suzuki–Miyaura and RCM reactions prompted us to investigate nonorganometallic-mediated reactions to see if the metal was in part responsible for the tremendous rate accelerations observed. An appealing choice for this study was nucleophilic aromatic substitution (NAS), given the wide use of this reaction in the preparation of biologically active compounds, both in academic and industrial labs (Scheme 2). In the three cases tested (Table 3), good to

Table 3. NAS Using Continuous Flow Microwave Microreactor

entry	reaction (solvent)	capillary diameter, ^a μm	power, W	flow rate, $\mu\text{L}/\text{min}$ (time)	product (% conversion ^b)
1	A	380	200	40 (3 min 54 s)	22 (72)
2	B (DMF)	380	170	30 (5 min 20 s)	23 (68)
3	B (DMF)	380 ^c	170	25 (5 min 47 s)	23 (100)
4	B (EtOH)	1150 ^c	170	40 (2 min 55 s)	23 (66)
5	C	1150	170	30 (4 min 13 s)	24 (68)
6	C	1150 ^c	170	25 (4 min 45 s)	24 (80)

^a Refers to the i.d. of the capillary. ^b Percent conversion was determined by ¹H NMR spectroscopy and is relative to residual starting material. ^c Pd-coated tube.

excellent conversions were realized when the reactions were performed with flow MW irradiation.

When Wilson and co-workers attempted NAS reactions using **21** and similar aryethylamines (albeit in a different solvent) they encountered a major problem.⁵ During the reaction, precipitation of the NAS product caused the reactor lines and frits to become clogged, necessitating termination of the reaction prior to complete consumption of the starting material. Significantly, no such problems occurred in the capillary reactor, despite similar crystallization of product during the reaction. Perhaps the success in our case, where others have struggled, has to do with the design of the reactor. Our reaction vessel (i.e., the capillary) is short and straight, whereas others are spiral,⁵ which is intended to increase the amount of time that the solution spends in the irradiation chamber. Irradiation time is further increased in these cases by flowing the reaction back and forth in order to complete it. In the examples examined so far using the capillary design, the reactions are completed relatively quickly, thus diminishing the time necessary to irradiate the sample, which may also aid in diminishing clogging issues.

Additionally, we successfully performed a Wittig reaction on aldehyde **25** based on a static literature MW procedure¹⁷ (Scheme 3) where the authors obtained 54% conversion after 5 min at 280 W in DMSO. They reported 28% conversion when the same reaction was refluxed in THF for 1 h. One very important observation is noteworthy in this reaction; it is heterogeneous. As discussed above, a constant source of worry with flow reactions is the presence of particulate matter that might plug the reactor, which could happen if precipitation occurs during the reaction. This reaction starts out with solids in it, yet there are no flow problems, and excellent conversion

(15) For discussion on palladium-catalyzed coupling reactions of aryl chlorides, see: Littke, A. F.; Fu, G. C. *Angew. Chem., Int. Ed.* **2002**, *41*, 4176–4211.

(16) Mayo, K. G.; Nearhoof, E. H.; Kiddle, J. J. *Org. Lett.* **2002**, *4*, 1567–1570.

(17) Frattina, S.; Quai, M.; Cereda, E. *Tetrahedron Lett.* **2001**, *42*, 6827–6829.

Scheme 3

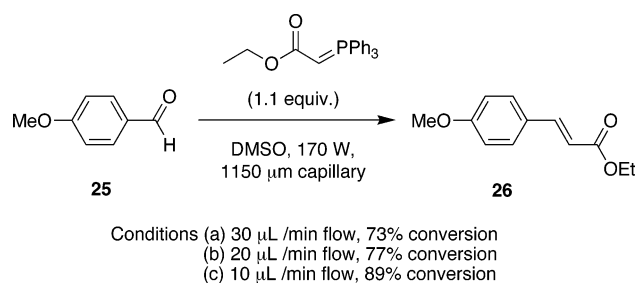

Scheme 4

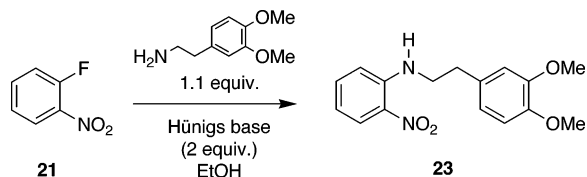

Table 4. Effect of Capillary Diameter, Flow Rate, MW Power Level, and Molarity on Reaction Conversion by Continuous Flow MW Irradiation

entry	power, W	capillary diameter, ^a μm	flow rate, $\mu\text{L}/\text{min}$	molarity ^b	% conversion ^c
1	150	200	30	0.43	47
2	150	326	30	0.43	55
3	150	380	30	0.43	60
4	150	1100–1200	30	0.43	57
5	150	380	15	0.43	76
6	150	380	45	0.43	57
7	150	380	60	0.43	54
8	200	380	30	0.43	61
9	100	380	30	0.43	58
10	50	380	30	0.43	41
11	150	380	30	0.23	52
12	150	380	30	0.74	66

^a Refers to the internal diameter of the capillary. ^b The molarity of the solution is based on the concentration of the aryl fluoride. ^c Percent conversion was determined by ^1H NMR spectroscopy and is relative to the residual fluoride.

is observed. Additionally, as will be further demonstrated in the following section, the conversion to product is significantly influenced by the flow rate.

Optimizing Flow Parameters. We broadened our investigation of the NAS involving **21** (Scheme 4) to include a systematic evaluation of capillary diameter, flow rate, power level, and molarity of the reaction (Table 4). It should be noted that the reactions in Table 4 are not directly comparable to those in Table 2, as the latter were performed using 2 equiv of the amine. In other words, these reactions are not necessarily optimized to go to completion, they are optimized to illustrate differences.

Increasing the capillary diameter (entries 1–4) resulted in improved conversions. This could be due either to the more efficient absorption of MW irradiation by the wider solution volume, which leads to a longer path for the irradiation to travel through the solution (i.e., the flow rate was unaltered), or to a longer time spent in the irradiation zone of the MW. Even more striking results were observed upon varying the flow rates (entries 3 and 5–7), whereby the conversion at 15 $\mu\text{L}/\text{min}$ was over 1.4 times greater than that at 60 $\mu\text{L}/\text{min}$. Increasing the power level (entries 3 and 8–10) was also accompanied by increased conversion. The molarity of the reaction (entries 3 and 11–12) also had a significant impact on conversion that

seems to follow conventional kinetics, i.e., the higher the concentration, the faster the reaction rate.

Flowing Reagents Together from Separate Syringes into the Capillary. A significant problem associated with microscale reactions is the dominance of laminar flow in the microchannels.^{2b} With microfluidic devices, there is a tendency for the two inlet streams to run side by side when they reach the central channel, leading to inefficient mixing and poor reaction. While a number of ingenious solutions to this problem have appeared in the literature,^{2b} we felt that the MW irradiation would promote diffusion and mixing so that this would not be a problem in our system. Two examples using this new technology are demonstrated in Scheme 5. In the first case, one inlet stream contained aryl fluoride **21** and base while the second one contained **27**, and these were pumped simultaneously through two inlets into the mixing chamber (Figure 1). The conjoined flows then moved into the capillary and through the irradiation chamber of the microwave. In this case, the conversion to product was actually slightly higher than that observed with one inlet stream using a stock solution (Table 3, entry 2).

Similarly, the biaryl coupling product **9** was prepared with excellent conversion when streams of bromide **6** and boronic acid **2** were fed independently into the capillary reactor. Neither reaction was adversely affected by this two-stream approach, showing that laminar flow is not an issue and sufficient mixing occurs regardless of how the reagents are brought together. The result obtained in these two cases mirror those obtained by completely premixing the reactions and then flowing and irradiating them (Tables 1 and 3).

These results have important significance for library synthesis. For practical considerations, every single reaction cannot be prepared as an individual mixture and flowed one at a time through the MW reactor. If this were the case, significant time and reaction vessels would be consumed in individual reaction preparation and the advantage of working in flow mode would be mostly lost. This is the major problem facing the use of static MW reactors at present. That is, the overall speed gained by irradiating reactions is lost to a large degree by preparing them one at a time, capping them one at a time, irradiating them one at a time, decapping them one at a time and working them up one at a time. In flow mode, the advantage of MW irradiation is still maintained, but there is the additional savings in time and cost by not using reaction flasks anymore. Further, a minimal number of stock solutions could be prepared and robotically fed through separate streams to produce an impressive array of final products.

Summary

In this report we have described a new method for carrying out organic reactions on a microscopic level in a continuous flow method. Reactions performed in capillaries with microwave irradiation showed dramatic rate enhancement compared to room-temperature reactions, illustrating that these small-volume reaction vessels are quite able to pick up the “microwave effect”. The quantity of material obtained using this methodology is directly proportional to the amount of time that the reaction is run. The system delivered more than 20 mg of product in one larger scale case examined and has the potential to deliver grams of product if desired. We have found that percent conversion

Scheme 5

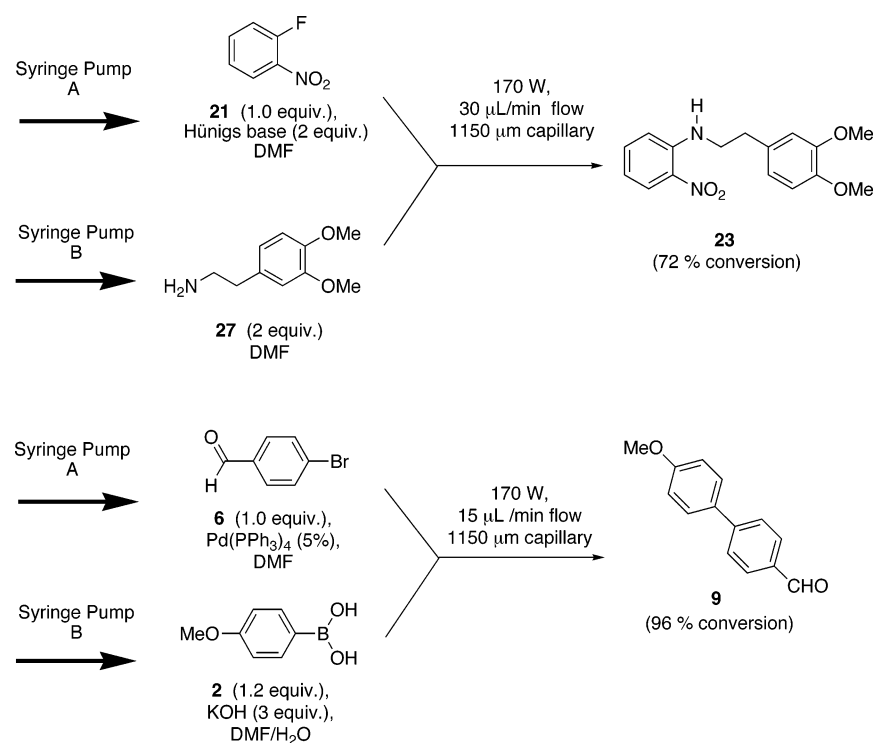

in capillary-irradiation-based reactions is influenced by flow rate, capillary internal diameter, power setting, metal coating in the capillary, molarity, and choice of solvent. Separate reaction components can be flowed into the capillary, where they mix and react, showing no signs of poor kinetics due to laminar flow. Reactions that contained particulate matter in them had no clogging problems, which is a very important consideration for the practical implementation of these microreactor devices in the field. We are also developing a multireactor system so that many reactions can be carried out in parallel. This methodology will also be applicable to continuous flow library preparation and combinatorial synthesis and we will publish on these efforts in due course.

Experimental Section

Suzuki–Miyaura Coupling Using Microwave-Assisted Capillary Organic Synthesis (MACOS). General Procedures. Single-Inlet Approach for Premixed Reactions. A stock solution containing the aryl halide (1 equiv, 0.2 M), arylboronic acid (1.2 equiv), base (3 equiv), and palladium catalyst in solvent was prepared. The continuous flow microwave system was primed with the same solvent as the stock solution. A 0.5-mL aliquot from the homogeneous stock solution was taken up in a Hamilton gastight syringe and connected to the reactor system as shown in Figure 1, with the aid of Microtight fittings. The syringe was placed in a Harvard 22 syringe pump that was set to deliver 2–30 μL/min (see Table 1 for specific conditions), and the single-mode microwave (Biotage Smith Creator Synthesizer) was programmed to heat constantly at the power level specified. The output from the reactor was fed into a collection tube and was analyzed directly by ¹H NMR spectroscopy immediately after reaction. All products are known and the ¹H NMR spectra obtained for compounds 3,¹⁸ 5,¹⁹ 8,²⁰ 9,²¹ 11,¹⁰

13,¹⁰ and 15²² are consistent with the literature data for these compounds. All compounds in this study have been isolated by silica gel chromatography for the purpose of spectroscopic identification.

Two-Inlet-Stream Approach for the Preparation of Compound 9. Stock solution “A” containing 4-bromobenzaldehyde (56 mg, 0.3 mmol, 1 equiv) and Pd(PPh₃)₄ (17 mg, 0.015 mmol, 5 mol %) in DMF (1.45 mL) was prepared, and a 0.5-mL portion was loaded into syringe “A”. A second stock solution, “B”, containing 4-methoxyphenylboronic acid (55 mg, 0.36 mmol, 1.2 equiv) and 2 M KOH (0.45 mL, 3.0 equiv, 0.9 mmol) in DMF (1 mL) was prepared, and a 0.5-mL portion was loaded into syringe “B”. The two syringes were placed in the same Harvard apparatus syringe pump that was set to deliver 15 μL/min, and the microwave was programmed to heat constantly at 170 W. The flow from the reactor was fed into a collection tube and was analyzed directly by ¹H NMR spectroscopy. Product 9¹⁹ is known, and its spectral data were consistent with literature values.

Ring-Closing Metathesis Using MACOS. General Procedure. A stock solution containing the diene precursor 17 or 19 and Grubb's II catalyst (1 mol %) in toluene or methylene chloride (0.15 M solution) was prepared. The continuous flow microwave reaction was performed using the same technique as above under the conditions outlined in Table 2. Product 18 is known and its ¹H NMR spectrum is consistent with that in the literature.²³ Product 20 was identical to a sample prepared previously in our laboratories.²⁴

Aromatic Substitution Reactions Using MACOS. General Procedure. A stock solution containing 2-fluoronitrobenzene (24, 1 equiv, 0.2 M), arylamine (2 equiv), and diisopropylamine (2 equiv) in solvent was prepared. The continuous flow microwave reaction was performed as above. Products 25,²⁵ 26,²⁶ and 27²⁷ are known, and their ¹H NMR data are consistent with literature values.

(18) Hayashi, T.; Inoue, K.; Taniguchi, N.; Ogasawara, M. *J. Am. Chem. Soc.* **2001**, *123*, 9918–9919.

(19) Gajewski, J. J.; Gee, K. R.; Jurajk, J. *J. Org. Chem.* **1990**, *55*, 1813–1822.

(20) Available from Aldrich.

(21) Tinnemans, A. H. A.; Laarhoven, W. H. *J. Am. Chem. Soc.* **1974**, *96*, 4611–4616.

(22) Anderson, J. C.; Nami, H.; Roberts, C. A. *Tetrahedron* **1997**, *53*, 15123–15134.

(23) Miller, S. J.; Kim, S.-H.; Chen, Z.-R.; Grubbs, R. H. *J. Am. Chem. Soc.* **1995**, *117*, 2108–2109.

(24) Organ, M. G.; Xu, J.; N'Zemba, B. M. *Tetrahedron Lett.* **2002**, *43*, 8177–8180.

Wittig Reaction Using MACOS. Preparation of Ethyl 3-(4-Methoxyphenyl)-2-propenoate (29). A stock suspension containing 4-methoxybenzaldehyde **25** (87 mg, 0.64 mmol, 1 equiv) and ethyl (triphenylphosphoranylidene)acetate (268 mg, 0.7 mmol, 1.1 equiv) in DMSO (2.4 mL) was prepared, and 0.5 mL was loaded into a syringe. The syringe was placed in a Harvard Apparatus syringe pump that was set to pump at 10–30 $\mu\text{L}/\text{min}$ and the single-mode microwave was

programmed to heat constantly at 170 W. The flow from the reactor was fed into a collection tube and was analyzed directly and immediately by ^1H NMR spectroscopy, which showed the formation of product **26**. Product **26**²⁸ is known, and its ^1H NMR data are consistent with the literature values.

Acknowledgment. This work was funded by NSERC Canada and the Ontario Research and Development Challenge Fund (ORDCF). The authors are grateful to Biotage Inc. for the donation of a Smith Creator Synthesizer to develop this new methodology.

JA0512069

-
- (25) Goetz, F. J.; Hirsch, J. A.; Augustine, R. L. *J. Org. Chem.* **1983**, *48*, 2468–2472.
(26) Beaulieu, P. L.; Hache, B.; Von Moos, E. *Synthesis* **2003**, *11*, 1683–1692.
(27) Zellner, H.; Zellner, G. *Helv. Chim. Acta* **1966**, *49*, 913–939.
(28) Qian, C.; Wang, L. *Tetrahedron* **2000**, *56*, 7193–7197.